

Flat suction cup, round

G10 - G60, soft design

FEZER
Simply move more.

Description

Very elastic rubber cup with smooth pad (G) or burling pad (GN) and single lip. The suction pads are clipped on and can be easily removed when worn out. Please order connection nipples separately.

Application

- workpieces with flat and even surface
- workpieces with extremely sensitive surfaces



FS-G 10 ... FS-G 60, FS-GN38 ... FS-GN 47

Article numbers

Type	NBR-S	SI-T	CR-W	Connection nipple	
				M5-A	G1/4-A
FS-G 10	1.01.1.0004	1.01.1.0007	1.01.1.0001	---	1.31.1.0002
FS-G 20	1.01.1.0017	1.01.1.0021	1.01.1.0015	1.31.1.0012	1.31.1.0011
FS-G 28	1.01.1.0030	1.01.1.0031	1.01.1.0029	1.31.1.0012	1.31.1.0011
FS-G 38	1.01.1.0050	1.01.1.0051	1.01.1.0049	1.31.1.0013	1.31.1.0014
FS-GN 38	1.01.1.0082	1.01.1.0083	1.01.1.0081	1.31.1.0013	1.31.1.0014
FS-G 47	1.01.1.0058	1.01.1.0059	1.01.1.0057	1.31.1.0013	1.31.1.0014
FS-GN 47	1.01.1.0085	1.01.1.0086	1.01.1.0084	1.31.1.0013	1.31.1.0014
FS-G 60	---	1.01.1.0072	1.01.1.0066	1.31.1.0006	1.31.1.0014

Technical details

Type	Holding force* (N)	Volume** (l)	Weight (kg)
FS-G 10	4	0,001	0,001
FS-G 20	13	0,001	0,001
FS-G 28	20	0,001	0,004
FS-G 38	46	0,002	0,004
FS-GN 38	45	0,002	0,004
FS-G 47	60	0,006	0,014
FS-GN 47	62	0,006	0,014
FS-G 60	93	0,014	0,016

* Specifications at 60 % vacuum w/o safety factor, on smooth, dry surfaces

** Volume with suction pad not engaged and unloaded

Flat suction cup, round

G10 - G60, soft design

FEZER
Simply move more.

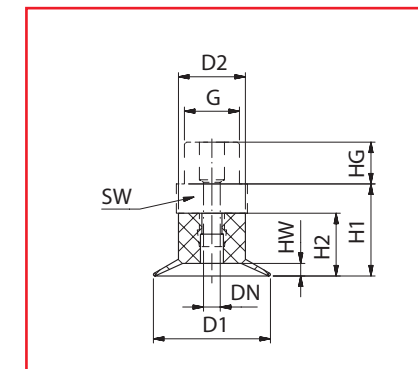

FS-G 10 ... FS-G 60

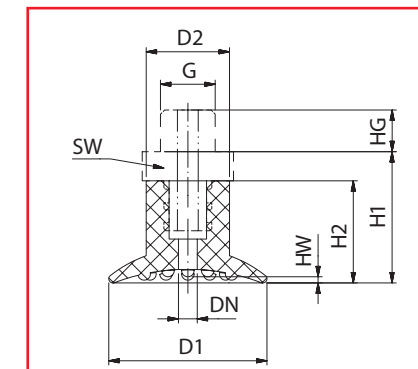

FS-GN 38 ... FS-GN 47

Dimensions

Type	D1	D2	DN	HW	H1	H2	HG	G	SW
FS-G 10	10	5	2,5	1,5	11	7,5	4,5	M5	8
FS-G 20	20	11,5	5,5	3	22	15	10	G1/4	17
FS-G 28	28	16	5,5	3	26	15	6	G1/4	17
FS-G 38	38	20	4,5	3,5	30,5	23,5	10	G1/4	19
FS-GN 38	38	20	4,5	4	30,5	23,5	10	G1/4	19
FS-G 47	47	20	4,5	5,5	33	26	10	G1/4	19
FS-GN 47	47	20	4,5	6	33	26	10	G1/4	19
FS-G 60	55	20	4	8	33	26	10	G1/4	19

Suitable connection elements

Type	Suction pad retainers		Holding bracket	Holders		Suspension bolt
	SAS	SAK		Bushing	Holding joint	
FS-G 10 ... FS-G28	SAS-M8x1-M5	---	HSW-M8x1-M5	HSB-M5-1/8	HSG-M8x1	FS ... -M8x1
FS-G 38 ... FS-G60	SAS-M12x1-1/4	---	HSW-M12x1-1/4	HSB-1/4-1/4	HSG-M12x1	FS ... -M12x1