

Bubble cap suction cup, round

GG 30 - GG 80

FEZER
Simply move more.

Description

Robust and resistant flat suction pad in bubble-cap design with inner pad. The suction pad has vulcanized connection nipple and is available in different materials.

Application

- workpieces with large curves and unevenness
- handling of chassis parts, also with oily surfaces



FS-GG 30 ... FS-GG 80

Article numbers

Type	NBR-G	SI-T
FS-GG 30	1.01.2.0073	1.01.2.0078
FS-GG 40	1.01.2.0074	1.01.2.0079
FS-GG 55	1.01.2.0075	1.01.2.0080
FS-GG 70	1.01.2.0076	1.01.2.0081
FS-GG 80	1.01.2.0077	1.01.2.0082

Technical details

Type	Holding force* (N)	Suction radius min: (mm)	Volume** (l)	Weight (g)
FS-GG 30	21	20	0,004	0,008
FS-GG 40	42	25	0,010	0,018
FS-GG 55	83	30	0,020	0,025
FS-GG 70	125	45	0,030	0,045
FS-GG 80	150	55	0,040	0,095

* Specifications at 60 % vacuum w/o safety factor, on smooth, dry surfaces

** Volume with suction pad not engaged and unloaded

Bubble cap suction cup, round

GG 30 - GG 80

FEZER
Simply move more.

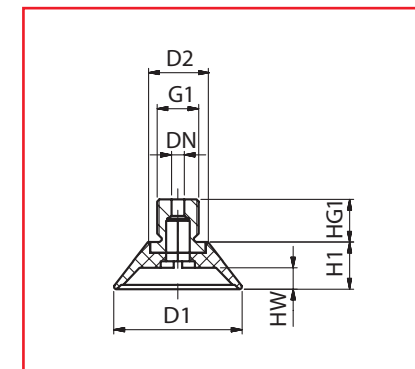

FS-GG 30 ... FS-GG 80

Dimensions

Type	D1	D2	DN	HW	H1	HG1	G1
FS-GG 30	30	15	3	5	11	10	G1/8
FS-GG 40	40	20	3	8	14	10	G1/8
FS-GG 55	55	30	3	9	23	10	G1/4
FS-GG 70	70	50	3	12	23	10	G1/4
FS-GG 80	80	55	3	9	22	10	G3/8

Suitable connection elements

Type	Suction pad retainer		Holding bracket	Holders		Suspension bolt
	SAS	SAK		Bushing	Holding joint	
FS-GG 30 ... FS-GG 40	SAS-M12x1-1/8	---	HSW-M12x1-1/8	HSB-1/8-1/8	HSG-M12x1-1/8	FS ... -M12x1
FS-GG 55 ... FS-GG 70	SAS-M12x1-1/4	---	HSW-M12x1-1/4	HSB-1/4-1/4	HSG-M12x1-1/4	FS ... -M12x1
FS-GG 80	SAS-M12x1-3/8	---	HSW-M12x1-3/8	HSB-3/8-3/8	HSG-M12x1-3/8	FS ... -M12x1