

## Rectangular suction plate

EP 30x100 - 50x300 with base plate

### Description

Robust and resistant holding plate with protruding base plate which allows to connect and exchange them from the top. The sealing is vulcanized onto the base plate.

### Application

- to screw onto holding tables with o-ring sealing
- also suitable for engagement of rods and tubes



EP 30x100 ... EP 100x300

### Article numbers

Type	NBR-G	SI-T	Connection screw	
			Type	
DP-EP 30x100	1.11.1.0012	1.11.1.0014	AS-M8-16	1.31.2.0076
DP-EP 30x200	1.11.1.0017	1.11.1.0018	AS-M8-16	1.31.2.0076
DP-EP 30x300	1.11.1.0021	1.11.1.0022	AS-M8-16	1.31.2.0076
DP-EP 40x100	1.11.1.0354	1.11.1.0415	AS-M8-16	1.31.2.0076
DP-EP 40x200	1.11.1.0355	1.11.1.0424	AS-M8-16	1.31.2.0076
DP-EP 40x300	1.11.1.0356	1.11.1.0425	AS-M8-16	1.31.2.0076
DP-EP 50x200	1.11.1.0357	1.11.1.0500	AS-M8-16	1.31.2.0076
DP-EP 50x300	1.11.1.0358	1.11.1.0501	AS-M8-16	1.31.2.0076

### Technical details

Type	Holding force* (N)	Suction radius min: (mm)	Volume** (l)	Weight (kg)
DP-EP 30x100	65	25	0,017	0,18
DP-EP 30x200	130	25	0,025	0,33
DP-EP 30x300	195	25	0,040	0,52
DP-EP 40x100	100	40	0,022	0,22
DP-EP 40x200	200	40	0,032	0,40
DP-EP 40x300	300	40	0,050	0,65
DP-EP 50x200	300	50	0,040	0,50
DP-EP 50x300	450	50	0,060	0,90

\* Specifications at 60 % vacuum w/o safety factor, on smooth, dry surfaces

\*\* Volume with suction pad not engaged and unloaded

## Rectangular suction plate

EP 20x100 - 50x300 with base plate

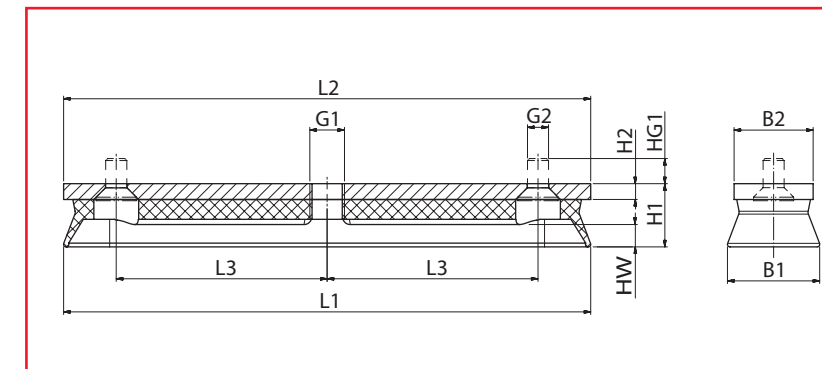

EP 30x100 ... EP 100x300

### Dimensions

Type	L1	L2	L3	B1	B2	HW	H1	H2	G1	G2
DP-EP 30x100	100	52	120	30	30	5	20	6	8,5	G1/8
DP-EP 30x200	200	102	220	30	30	5	20	6	8,5	G1/8
DP-EP 30x300	300	152	320	30	30	5	20	6	8,5	G1/8
DP-EP 40x100	100	52	120	40	30	6	22	6	8,5	G1/4
DP-EP 40x200	200	102	220	40	30	6	22	6	8,5	G1/4
DP-EP 40x300	300	152	320	40	30	6	22	6	8,5	G1/4
DP-EP 50x200	200	102	220	50	40	6	27	6	8,5	G1/4
DP-EP 50x300	300	152	320	50	40	6	27	6	8,5	G1/4