

Structure suction plate, oval

FSM 75x180 - FSM 250x460

FEZER

Simply move more.

Description

Flat suction plate with aluminum body in oval design with pushed-in froth rubber sealing and grooved pad. The suction plate has a very soft sealing and are available with central vacuum connection. When worn out the sealing can be easily exchanged. The sealing plate is screwed on with 2 screws and double connection on 2 suspension bolts. Please order connection screws separately.

Application

- narrow workpieces with very rough or structured surface like wooden planks
- structures up to 2 mm height possible
- increased contact pressure required for suction



FSM 75x180 ... FSM 250x460

Article numbers

Type	Suction plate M-G	Replacement gasket M-G	Replacement pad NBR-G	Connection screw	
				Type	Art.-Nr:
FSM 75x180	1.13.1.0324	2.13.2.0093	2.13.2.0167	ASB-M16-20	1.31.2.0084
FSM 80x460	1.13.1.0310	2.13.2.0160	2.13.2.0165	AS-M16-22	1.31.2.0035
FSM 100x460	1.13.1.0311	2.13.2.0037	2.13.2.0166	AS-M16-22	1.31.2.0035
FSM 120x460	1.13.1.0217	2.13.2.0038	2.13.2.0168	AS-M16-22	1.31.2.0035
FSM 170x460	1.13.1.0313	2.13.2.0040	2.13.2.0169	AS-M16-22	1.31.2.0035
FSM 250x460	1.13.1.0314	2.13.2.0041	2.13.2.0170	AS-M16-22	1.31.2.0035

Technical details

Type	Holding force* (N)	Volume** (l)	Weight (kg)
FSM 75x180	430	0,11	0,52
FSM 80x460	1130	0,20	1,37
FSM 100x460	1720	0,39	1,72
FSM 120x460	2200	0,58	2,05
FSM 170x460	3400	0,88	2,90
FSM 250x460	5420	1,25	4,25

* Specifications at 60 % vacuum w/o safety factor, on smooth, dry surfaces

** Volume with suction pad not engaged and unloaded

Structure suction plate, oval

FSM 75x180 - FSM 250x460

FEZER

Simply move more.

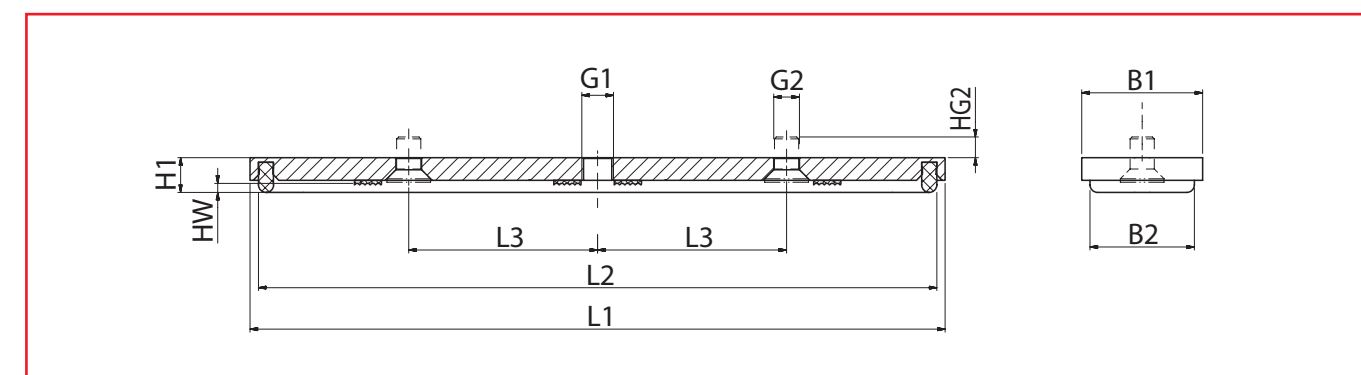

FSM 75x180 ... FSM 250x460

Dimensions

Type	L1	L2	L3	B1	B2	HW	H1	HG1	HG2	G1	G2
FSM 75x180	180	170	---	75	65	6	23	---	---	17	---
FSM 80x460	460	450	125	80	70	6	23	---	10	G1/2	16,2
FSM 100x460	460	450	125	100	90	6	23	---	10	G1/2	16,2
FSM 120x460	460	450	125	120	110	6	23	---	10	G1/2	16,2
FSM 170x460	460	450	125	170	160	6	23	---	10	G1/2	16,2
FSM 250x460	460	450	125	250	240	6	23	---	10	G1/2	16,2

Suitable connection elements

Type	Suction pad retainer		Suspension bolt
	SAS	SAK	
FSM 75x180	SAS-M16x1,5-M16	---	FS ... -M16x1,5*
FSM 80x460 ... FSM 120x460	SAS-M16x1,5-M16	SAK-M16x1,5-M16	FS ... -M16x1,5**
FSM 170x460 ... FSM 250x460	SAS-M20x1,5-M16	SAK-M20x1,5-M16	FS ... -M20x1,5**

* Single connection, mounted with rotation-protected suspension bolt

** Double connection, mounted with 2 suspension bolts